

558 Series

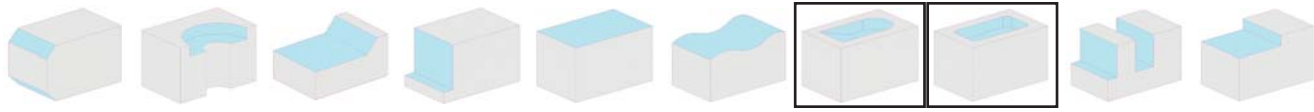

Note: Tools ending with "T" indicate **taper** tools



"T" Type Shank

Standard shank shown with "LCEG" insert



- Extended Reach
- 2 effective
- Collet Mount Configuration
- Thru Coolant also available

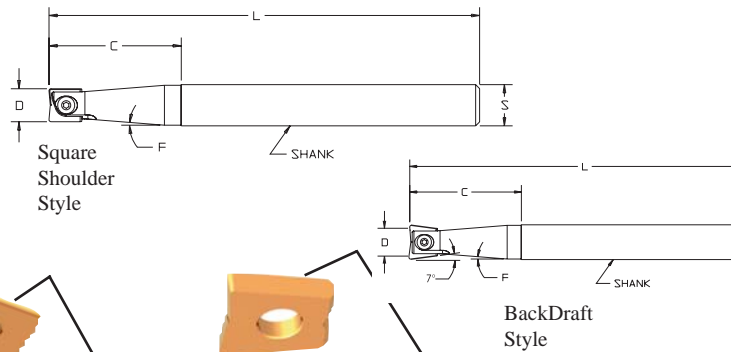

558 Series Dimensional Specifications

Product Number	D	S	C	L	F	Insert	Screw	Wrench
558E0050ASC4-S050R	.500	.500	1.250	3.562	N / A	LCEA / G-41.5__ ZCEA / G-41.5__	GWS 12	1557-TX15
558E0050BSC4-S050R	.500	.500	1.250	5.125	N / A	LCEA / G-41.5__ ZCEA / G-41.5__	GWS 12	1557-TX15
558E0050CSC4-S050R	.500	.500	1.812	5.875	3°	LCEA / G-41.5__ ZCEA / G-41.5__	GWS 12	1557-TX15
558E0050DSC4-S062RT	.500	.625	2.312	6.281	N / A	LCEA / G-41.5__ ZCEA / G-41.5__	GWS 12	1557-TX15
558E0062ASC5-S062R	.625	.625	1.375	5.500	N / A	LCEA / G-52__ ZCEA / G-52__	GWS 16	1557-TX15
558E0062BSC5-S062R	.625	.625	2.000	6.281	N / A	LCEA / G-52__ ZCEA / G-52__	GWS 16	1557-TX15
558E0075ASC6-S075R	.750	.750	1.750	4.500	N / A	LCEA / G-62__ ZCEA / G-62__	GWS 20	1557-TX20
558E0075BSC6-S075R	.750	.750	1.750	6.281	N / A	LCEA / G-62__ ZCEA / G-62__	GWS 20	1557-TX20
558E0075CSC6-S075R	.750	.750	2.375	6.875	N / A	LCEA / G-62__ ZCEA / G-62__	GWS 20	1557-TX20
558E0075ESC6-S075R	.750	.750	2.375	8.250	N / A	LCEA / G-62__ ZCEA / G-62__	GWS 20	1557-TX20
558E0075FSC6-S100RT	.750	1.000	3.000	9.437	3°	LCEA / G-62__ ZCEA / G-62__	GWS 20	1557-TX20
558E0100ASC8-S100R	1.000	1.000	1.750	6.281	N / A	LCEA / G-82.5__ ZCEA / G-82.5__	GWS 25	1557-TX25
558E0100BSC8-S100R	1.000	1.000	2.750	7.500	N / A	LCEA / G-82.5__ ZCEA / G-82.5__	GWS 25	1557-TX25
558E0100CSC8-S125RT	1.000	1.250	3.875	9.437	3°	LCEA / G-82.5__ ZCEA / G-82.5__	GWS 25	1557-TX25
558E0100DSC8-S100R	1.000	1.000	3.125	9.062	N / A	LCEA / G-82.5__ ZCEA / G-82.5__	GWS 25	1557-TX25

Insert I.C. x Thickness						
	Insert Pg. 36	Insert Pg. 36	BackDraft Style Insert Pg. 48	BackDraft Style Insert Pg. 48	Insert Screw Wrench	Insert Screw
.500 x .098	LCEA-41.5__	LCEG-41.5__	ZCEA-41.5__	ZCEG-41.5__	(see table above)	(see table above)
.625 x .118	LCEA-52__	LCEG-52__	ZCEA-52__	ZCEG-52__	(see table above)	(see table above)
.750 x .118	LCEA-62__	LCEG-62__	ZCEA-62__	ZCEG-62__	(see table above)	(see table above)
1.000 x .157	LCEA-82.5__	LCEG-82.5__	ZCEA-82.5__	ZCEG-82.5__	(see table above)	(see table above)

- Uniquely designed single insert that offers two cutting edges
- Wide offering of small and medium diameters with various extensions available
- Accurate repeatability after insert replacement



Index

Specials

Inserts

General

Cavity Mold

Gray Iron

PCD / CBN

Slotters

Technical
Data

Holders